

MODEL E DRAIN CLEANING MACHINE

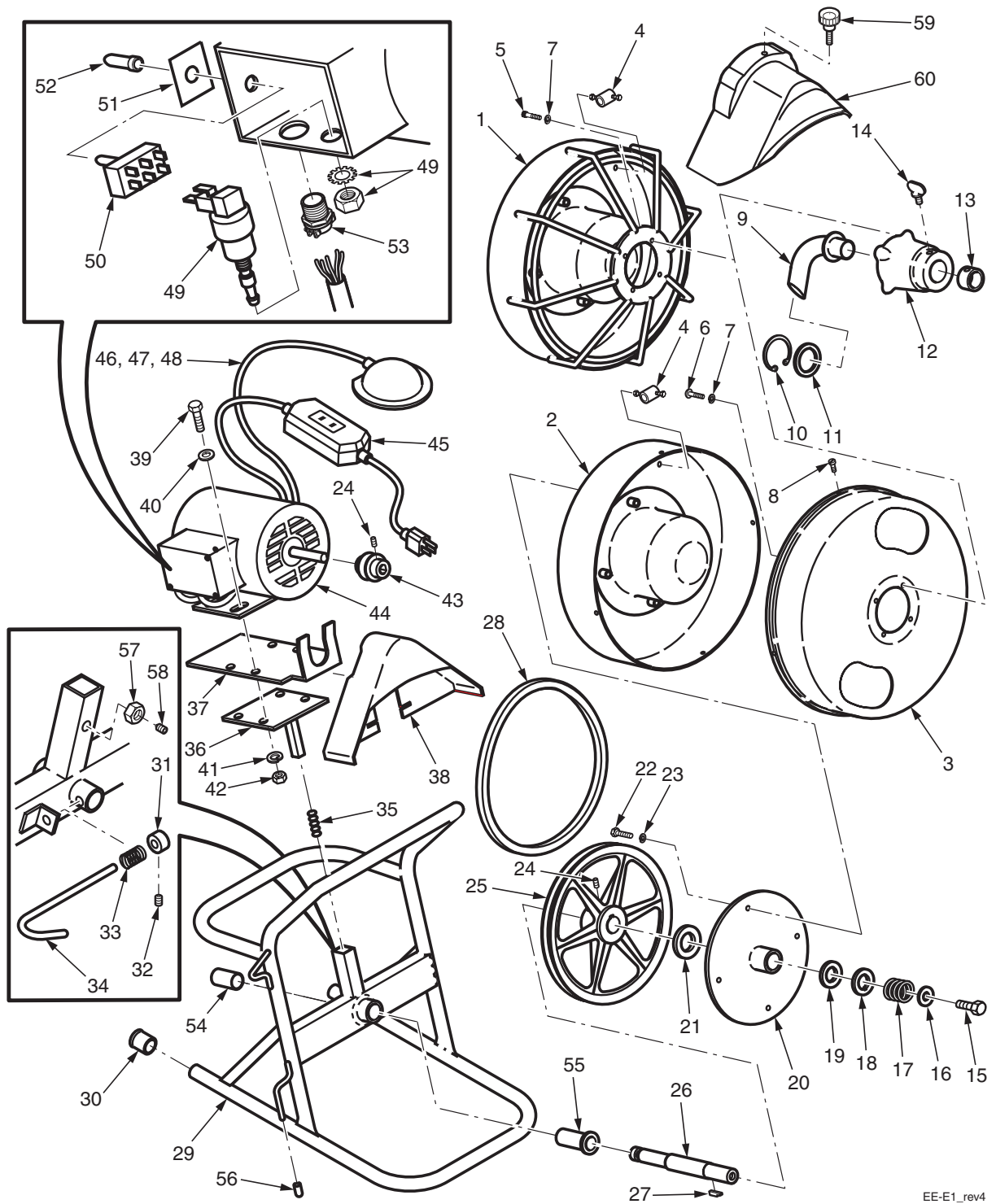

EE-E1_rev4

MODEL E DRAIN CLEANING MACHINE

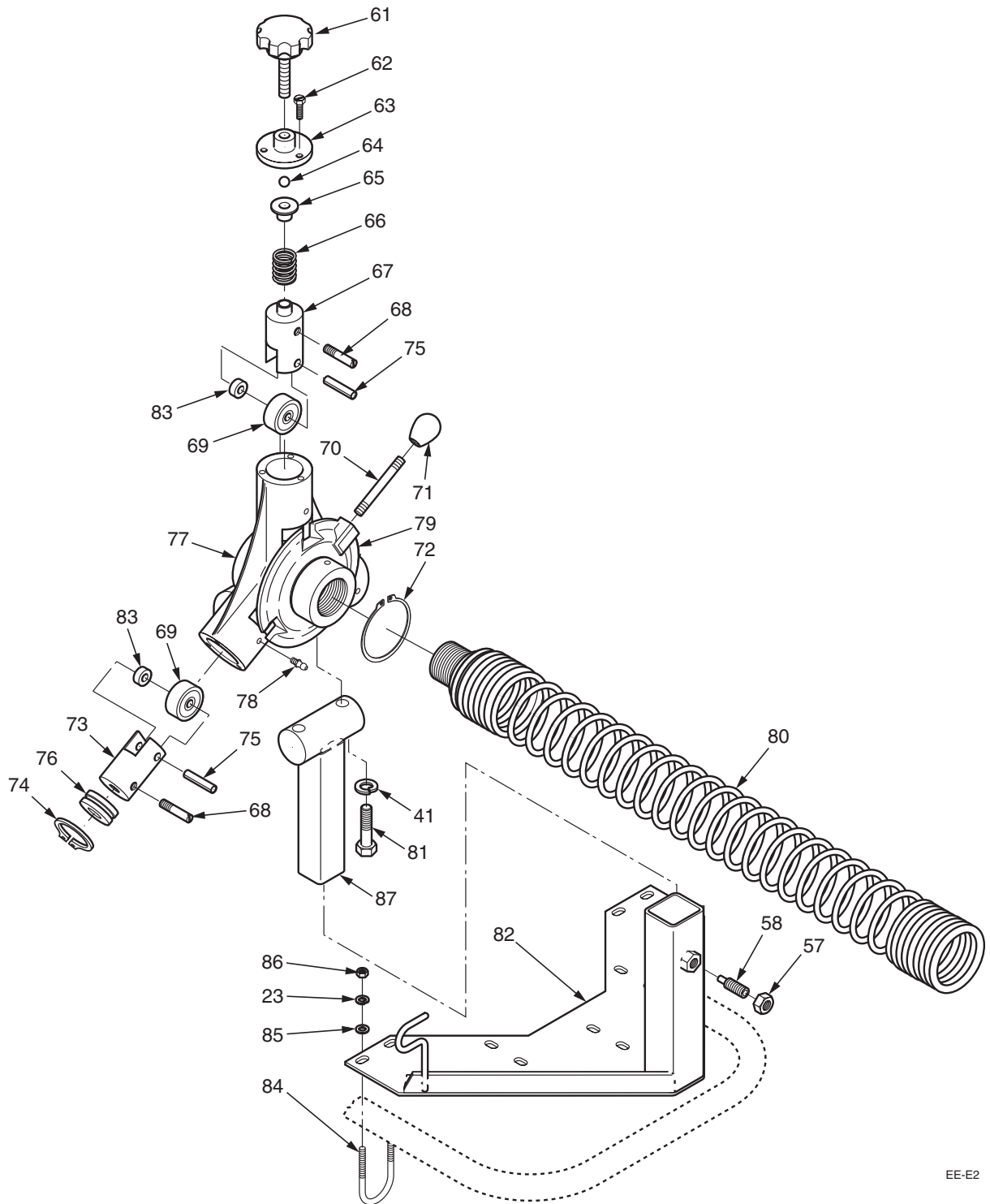

EE-E2

MODEL E DRAIN CLEANING MACHINE

ITEM NUMBER	PART NUMBER	DESCRIPTION	AMT
1	ED-3 (See Note 1)	Welded Drum/Cage Assembly	1
2	ED-1 (See Note 1)	Rear Cable Drum w/Inner Drum	1
3	ED-2	Front Cable Drum	1
4	DN-6	Cable Anchor (used with ED-1 only)	1
5	MS102412HH	10-24 x 1/2 Hex Head Machine Screw	4
6	MS102438RH	10-24 x 3/8 Round Head Machine Screw	4
7	LW10	Lockwasher	4
8	MS83214SS	Stainless Steel Metal Screw	4
	ED-4A (See Note 2)	Guide Tube and Bracket Assembly	1
9	ED-4	Guide Tube	1
10	RR175	Retaining Ring	1
11	N-5-4	Retaining Washer	1
12	ED-5	Bracket	1
13	ED-6	Collar	1
14	WS516	5/16-18 Wing Screw	1
	EE-1A (See Note 3)	Drive Assembly w/Clutch	1
15	CSHH12201	1/2-20 x 1 Hex Head Capscrew	1
16	WA716P	Flatwasher	1
17	N-14	Spring	1
18	EE-3	Drive Disc	1
19	EE-4	Front Friction Disc	1
20	EE-2	Drum Mounting Plate	1
21	EE-5	Rear Friction Disc	1
22	CSHH142034	1/4-20 x 3/4 Hex Head Capscrew	4
23	LW14	1/4 Lockwasher	4
24	SS51618516	5/16-18 x 5/16 Set Screw	2
25	EE-6	10" Pulley	1
26	EE-1	Drive Shaft	1
27	N-15	Clutch Key	1
28	4L390	V-Belt	1
	EF-1A (See Note 4)	Frame Assembly	1
29	EF-1	Welded Frame	1
30	EE-14	Rubber Tips	2
31	EE-8	Retainer Pin Collar	1
32	SS103218	10-32 x 1/8 Set Screw	1
33	EE-15	Retainer Pin Spring	1
34	EE-7	Retainer Pin	1
35	EE-9	Motor Tension Spring	1
36	R23 (See Note 5)	Motor Mount	1
37	R22 (See Note 5)	Adapter Plate	1
38	EE-16	Belt Guard	1
39	CSHH516181	Motor Mount Capscrews	4
40	WA516S	Motor Mount Flatwashers	4

MODEL E DRAIN CLEANING MACHINE

ITEM NUMBER	PART NUMBER	DESCRIPTION	AMT
41	LW516	5/16 Lockwasher	2
42	NU51618FHP	Motor Mount Nuts.	4
43	N-8	Motor Pulley	1
44	EM-1/3	1/3 H.P. Motor w/Fwd-Rev Switch	1
45	GFCI	Ground Fault Circuit Interrupter w/Cord	1
46	FP-1A (See Note 6)	Air Foot Pedal Transmitter w/Air Hose	1
47	FP-1	Foot Pedal Only.	1
48	FP-2	Air Hose Only	1
49	TBS3218	Air Activated On/Off Switch.	1
50	SW-FO	Forward/Off Switch	1
51	SW-FOP	Forward/Off Switch Plate	1
52	SW-BOOT	Toggle Switch Boot.	1
53	TSC12	Two-Screw Connector.	1
54	0BSS243220	Rear Bronze Bushing	1
55	0BSF243216	Front Bronze Bushing	1
56	DL6CAP	Cord Hook Cap	2
57	NU51624FHP (See Note 7)	5/16-24 Hex Nut	1
58	SS5162458DP	5/16-24 x 5/8 Dog Point Set Screw.	1
59	TS14 (See Note 7)	Thumb Screw	1
60	EE-16 (See Note 8)	Belt Guard	
61	FE-4	Tension Handle	1
62	CSSH83212	8-32 x 1/2 Socket Head Cap Screw.	3
63	FE-3	Top Feeder Cap	1
64	BB-38	3/8" Ball Bearing.	1
65	DE-8	Ball Baring Retainer	1
66	FE-5	Tension Spring.	1
67	FE-6	Top Feeder Insert.	1
68	DE-12	Feeder Control Fingers	3
69	FE-7	Feeder Bearing	3
70	DE-13	Control Lever	1
71	DE-14	Control Lever Knob.	1
72	RR168	Retaining Ring	1
73	FE-8	Lower Feeder Insert.	2
74	RR100	Retaining Ring	2
75	RP5161516	5/16 x 1" Roll Pin	3
76	FE-9	Control Bearings	2
77	FE-1	Feeder Body	1
78	GZ1428S	Grease Zerk 1/4-28 Short	3
79	FE-2	Feeder Control Plate	1
80	EZ-GTA	Guide Spring Assembly	1
81	CSHH51618112	5/16-18 x 1 1/2 Hex Head Cap Screw.	2
82	EZ-1A	Auto Feed Base	1
83	3145181	Spacer	3
84	UB1420	1/4-20X U Bolt	4

MODEL E DRAIN CLEANING MACHINE

ITEM NUMBER	PART NUMBER	DESCRIPTION	AMT
85	WA14S	1/4" Flatwasher	4
86	NU1420FHP	1/4-20 Hex Nut	4
87	EZ-2A	Feeder Mounting Post Assy	1

Note:

- 1 Includes Item 4
- 2 Includes Items 9-14
- 3 Includes Items 15-27
- 4 Includes Items 29-37 and 54-58
- 5 Prior to Serial No. 6629, Item 36 part no. is EE-10 and Item 37 part no. is EE-11.
- 6 Includes Items 47 and 48
- 7 Added to assembly, beginning with Serial No. 8141.
- 8 Added to assembly Dec. 2007 and after